

THIS DRAWING IS UNPUBLISHED. RELEASED FOR PUBLICATION  
 © COPYRIGHT - By - ALL RIGHTS RESERVED.

| LOC | DIST | REVISIONS |     |                           |         |     |      |
|-----|------|-----------|-----|---------------------------|---------|-----|------|
|     |      | P         | LTR | DESCRIPTION               | DATE    | DWN | APVD |
| G   | 14   |           | G2  | REVISED PER ECO-11-004587 | 11MAR11 | RK  | HMR  |

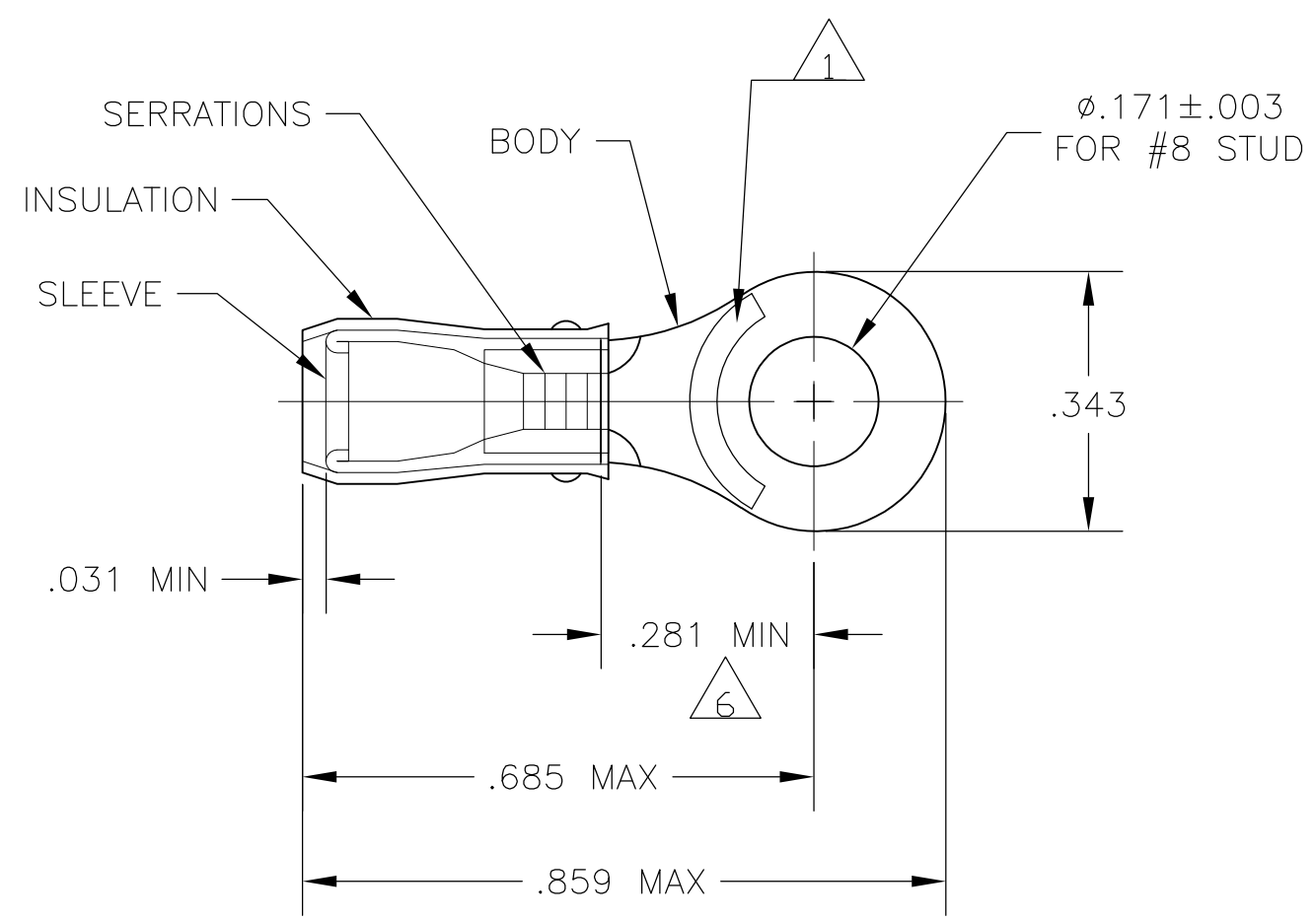

- 1 STAMP AMP 16-14\* APPROX AS SHOWN
- 2 WIRE INSULATION DIA: .115-.170
- 3 TONGUE MATERIAL THK: .031±.002
- 4 BODY & SLEEVE: TIN PLATE PER ASTM B545,
- 5 BODY & SLEEVE- CU PER ASTM B152 INSULATION - NYLON, COLOR - BLUE
- 6 APPLIES FROM EDGE OF METAL WIRE BARREL TO CENTER OF STUD HOLE.

|      |                  |            |
|------|------------------|------------|
| 100  | LOOSE PIECE, BOX | 8-320565-1 |
| 5000 | 320565 ON TAPE   | 2-320565-1 |
| 1000 | LOOSE PIECE      | 320565     |
| QTY  | PACKAGE TYPE     | PART NO    |

|  |  |   |  |   |                                 |                            |       |           |   |               |
|--|--|---|--|---|---------------------------------|----------------------------|-------|-----------|---|---------------|
| AMP INCORPORATED<br>CUSTOMER SERVICE SYSTEMS                                     |  | MAX RECOMMENDED OPERATING TEMPERATURE:<br>105°C MAX   | THIS DRAWING IS A CONTROLLED DOCUMENT. |   | DWN<br>JR RUTH<br>16JAN07       | <b>STE</b> TE Connectivity |       |           |   |               |
| FOR ADDITIONAL PRODUCT INFORMATION OR COPIES OF DRAWINGS AND TECHNICAL DOCUMENTS | PRODUCT INFORMATION CENTER<br>1-800-522-6752 | VOLTAGE RATING:<br>-  | DIMENSIONS:<br>INCHES                  | TOLERANCES UNLESS OTHERWISE SPECIFIED:                                      | CHK<br>T MICHELUTTI<br>16JAN07  |                            |       |           | NAME<br>TERMINAL, RING TONGUE, P.I.D.G.<br>WIRE SIZE: 16-14 AWG |               |
| FOR APPLICATION TOOLING INFORMATION  | TOOLING ASSISTANCE CENTER<br>1-800-722-1111  | CIRCULAR MIL AREA:<br>1.04-2.62mm <sup>2</sup> [2,050-5,180] STRANDED   |  | 0 PLC ± -<br>1 PLC ± -<br>2 PLC ± -<br>3 PLC ± -<br>4 PLC ± -<br>ANGLES ± - | APVD<br>T MICHELUTTI<br>16JAN07 | PRODUCT SPEC               | SIZE  | CAGE CODE | DRAWING NO  | RESTRICTED TO |
| FOR ORDER ENTRY  | 1-800-526-5142                               | THIS DRAWING IS A CONTROLLED DOCUMENT FOR AMP INCORPORATED. IT IS SUBJECT TO CHANGE AND THE CONTROLLING ENGINEERING ORGANIZATION SHOULD BE CONTACTED FOR THE LATEST REVISION. | MATERIAL<br>- 5                        | FINISH<br>- 4   | WEIGHT<br>-                     | APPLICATION SPEC           | A3    | 00779     | G-320565  | -             |
| CUSTOMER DRAWING   |  |   |  |   | SCALE                           | 4:1                        | SHEET | 1 OF 1    | REV   | G2            |