

PART NUMBER	REV	FIRST USED
567846-1	D	854040-4

AMP P/N		MFG P/N		VISIBLE	CRIMPING DATA	
286522		8230-4502		PAD LTR	CRIMP HEIGHT	WIRE SIZE
				A	.059 ±.002 [1.5 ±0.05mm]	1.25mm ²
				B	.052 ±.002 [1.32 ±0.05mm]	.85 mm ²
				C	.048 ±.002 [1.22 ±0.05mm]	0.5 mm ²
				D	NOT	USED
CRIMP		SIZE	TYPE	RANGE		
WIRE		.085 [2.16mm]	F	0.5 - 1.25 mm ²		
INSUL		.105 [2.67mm]	F			
WIRE STRIP LENGTH	TERM APPL SPEC	FEED	APPL INSTRUCTION	SET UP GAGE	LAYOUT	
-	NONE	.391	SEE CUSTOMER MANUAL	NONE	L1828	

STANDARD FORCE CRIMP QUALITY MONITOR APPLICATOR

SIM REG S/C NONE						
QTY	REV	REV	REV	REV	REV	REV
						70
						69
						68
						67
						66
						65
						64
						63
						62
						61
						60
						59
						58
						57
						56
						55
						54
						53
						52
						51
						50
						49
						48
						47
						46
						45
						44
						43
						42
						41
						40
						39
						38
						37
						36
						35
						34
						33
						32
						31
						30
						29
						28
						27
						26
						25
						24
						23
						22
						21
						20
						19
						18
						17
						16
						15
						14
						13
						12
						11
						10
						9
						8
						7
						6
						5
						4
						3
						2
						1

QTY	REV	REV	REV	REV	REV	REV
2	-	C	3-354779-4	PIN, WIRE DISC (.3160)D	129	
2	-	C	1-354779-9	PIN, WIRE DISC (.3085)C	128	
					127	
2	-	C	4-354779-4	PIN, WIRE DISC (.3210)A	126	
1	-	A	986950-1	WASHER, FLAT PRECISION	125	
1	-	A	217238-4	GENERAL INSTRUCTION PACKAGE	124	
					123	
					122	
					121	
					120	
1	-	B	690701-2	PLATE, SERIAL NO.	120	
2	-	A	21899-2	WASHER, FLAT (#10)S G ADJ BLK	119	
					118	
2	-	A	21024-5	WASHER, LOCK (#10)ADJ BLOCK	117	
					116	
					115	
2	-	A	21024-2	WASHER, LOCK (#4)FRONT STP GUIDE	114	
REF	-	A	21024-4	WASHER, LOCK (#8)FEED FINGER	113	
2	-	A	21024-4	WASHER, LOCK (#8)DEP-HOLD	112	
REF	-	A	21024-4	WASHER, LOCK (#8)STRIPPER	111	
					110	
					109	
1	-	A	21018-5	NUT, HEX (#6)HOLD DOWN	108	
					107	
					106	
					105	
					104	
1	-	A	21009-2	SCR, SKT 5ET (1/4-20x.25 LW)RAM	103	
					102	
4	-	A	21017-2	SCR, DRIVE (#2x.19)ID PLATE	101	
1	-	B	819347-1	PLATE, IDENTIFICATION	100	
2	-	A	3-21002-0	SCR, BHC (10-32x.88)DRAG	99	
1	-	A	22733-8	SCR, BHC (8-32x.38 LW)ANVIL	98	
					97	
1	-	A	3-21000-8	SCR, SHC (10-32x.88)MOUNTING	96	
1	-	A	2-21002-7	SCR, BHC (10-32x.50)S6 ADJ BLK	95	
4	-	A	2-21002-2	SCR, BHC (8-32x.50)SHEAR-TERM SUP	94	
2	-	A	2-21002-1	SCR, BHC (8-32x.38)SH HLD	93	
					92	
1	-	A	1-21002-7	SCR, SHC (6-32x.50)CAM	91	
4	-	A	2-21000-8	SCR, SHC (8-32x.62)SCR BLK	90	
					89	
					88	
					87	
REF	-	A	2-22603-0	SCR, HEX HD (8-32x.31)FEED FINGER	86	
2	-	A	1-21000-3	SCR, SHC (4-40x.25)F ST GUIDE	85	
REF	-	A	22733-9	SCR, BHC (8-32x.50 SL)STRIPPER	84	
					83	
					82	
1	-	A	3-22603-1	SCR, HEX (10-32x.38)S6 ADJ BL	81	
					80	
					79	
					78	
2	-	B	463310-4	BLADE, STRIPPING (#18)	77	
-	-	D	354440-3	FFC LOOP ASSY	76	
					75	
1	-	A	690603-1	SPRING, ASSIST	74	
1	-	A	23030-1	SCR, SKT CAP (6-32x.25)CP DSC	73	
					72	
2	-	B	853495-1	GASKET	71	
					70	

QTY	REV	REV	REV	REV	REV	REV
-1	U/M	DWG SIZE	PART NO	DESCRIPTION	ITEM NO	
PARTS LIST						
QTY REOD PER ASSY						

QTY	REV	REV	REV	REV	REV	REV
-1	U/M	DWG SIZE	PART NO	DESCRIPTION	ITEM NO	
PARTS LIST						
QTY REOD PER ASSY						
REVISION OF EACH ASSY NO (WHEN BLANK, USE DWG REVISION)						

THIS DRAWING IS A CONTROLLED DOCUMENT.

THIS DRAWING IS UNRELEASED. RELEASE FOR PUBLICATION JUN 16, 1998 BY AMP INCORPORATED. ALL RIGHTS RESERVED.

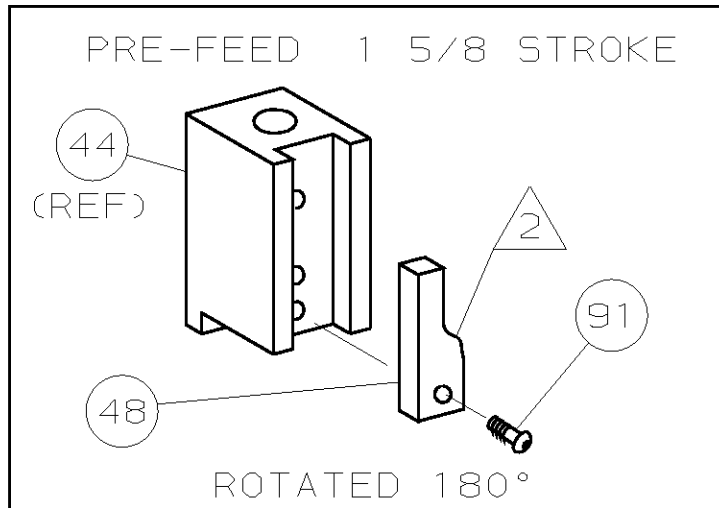
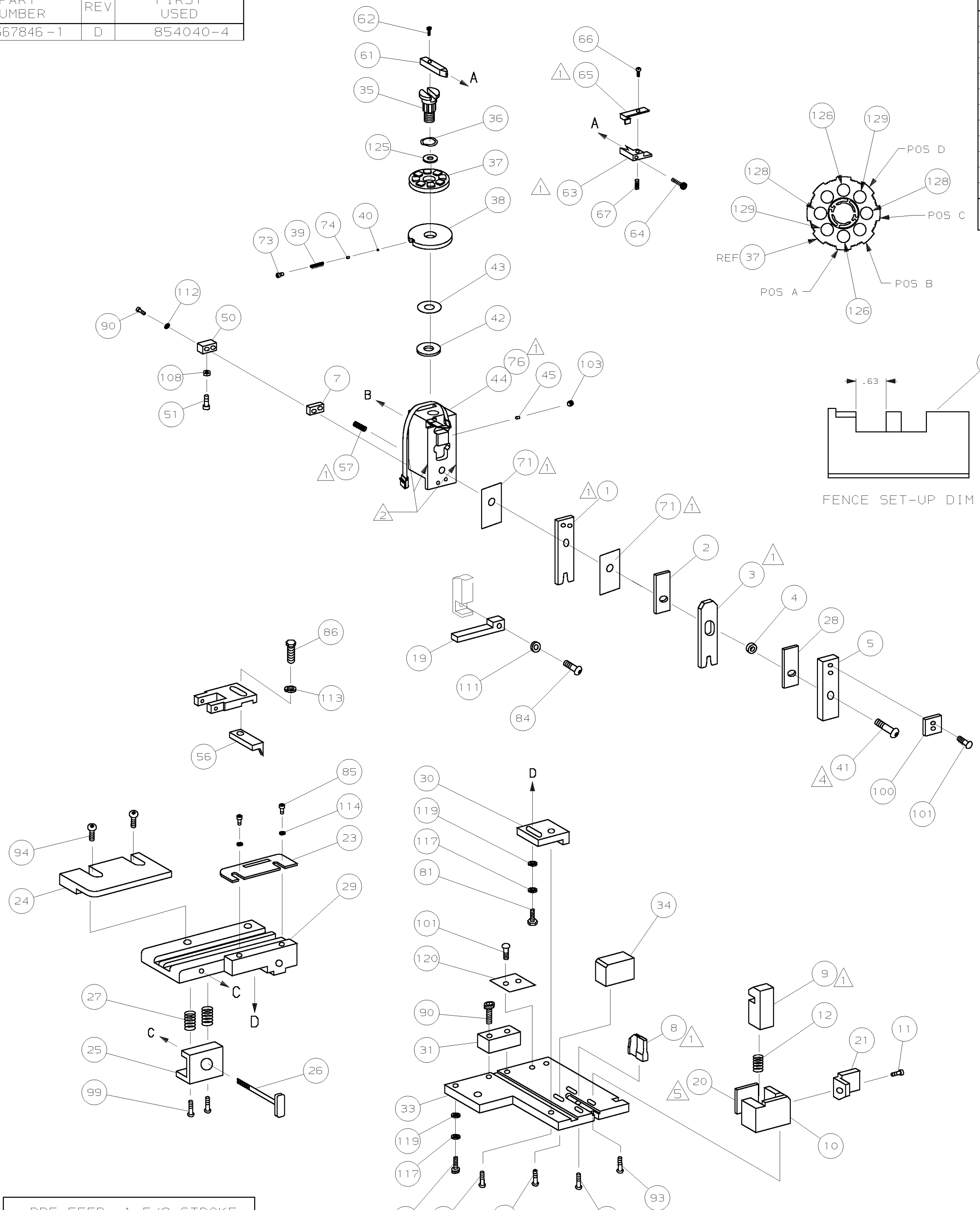

- 1 RECOMMENDED SPARE PARTS.
- 2 GREASE LIGHTLY.
- 3 ITEM NOT SHOWN
- 4 TORQUE ITEM 41 TO 60 INCH POUNDS
- 5 USE LOCTITE SUPERBOND TO ADHERE ITEM 20 INSIDE SLOT IN BASE PLATE IN FRONT OF ANVIL.